

Incorporating Rigidity and Commitment in the Timing Structure of Macroeconomic Games¹

Jan Libich²

La Trobe University, Dep. of Economics and Finance, and CAMA, ANU

Petr Stehlík³

University of West Bohemia, Department of Mathematics

Abstract

This paper proposes a novel framework that generalizes the timing structure of games. Building on alternating move games and models of rational inattention, the players' actions may be rigid, ie *infrequent*. This rigidity in the timing of moves makes the game more dynamic and asynchronous, acting as a commitment mechanism. Therefore, it can enhance cooperation and often eliminate inefficient equilibrium outcomes present in the static (normal form) game. Interestingly, (i) this can happen even in a finite game (possibly as short as two periods) and (ii) without reputation building. Furthermore, (iii) the required degree of commitment may be under some circumstances arbitrarily low and under others infinitely high. Our main example comes from macroeconomics in which various rigidities have played a central role. Investigating the Kydland-Prescott-Barro-Gordon monetary policy game, we derive the necessary and sufficient degree of long-term policy commitment to low inflation under which the influential time-inconsistency problem is eliminated.

Keywords: asynchronous moves, dynamic games, commitment, rigidity, time-inconsistency, inflation targeting, central bank independence

JEL classification: C70, C72, E42, E61

'Some decisions by economic agents are reconsidered daily or hourly, while others are reviewed at intervals of a year or longer... It would be desirable in principle to allow for differences among variables in frequencies of change and even to make these frequencies endogenous. But at present, models of such realism seem beyond the power of our analytical tools'.

Tobin (1982) (quoted in Reis (2006)).

¹We thank Damien Eldridge, Andrew Hughes Hallett, Jonathan Kearns, Glenn Otto, Jeff Sheen and the participants of the 23rd Australasian Economic Theory Workshop, 10th Australasian Macroeconomics Workshop, 34th Australian Conference of Economists, and seminars at the University of New South Wales, La Trobe University, University of Bayreuth, and University of Queensland. Both authors gratefully acknowledge the support by the Australian Research Council (DP0879638), and the Ministry of Education, Youth and Sports of the Czech Republic (MSM 4977751301). The usual disclaimer applies.

²Corresponding author: Dr Jan Libich, La Trobe University, School of Business, Melbourne, Victoria, 3086, Australia. Phone: (+61) 3 94792754, Fax: (+61) 3 94791654, Email: j.libich@latrobe.edu.au.

³University of West Bohemia, Univerzitní 22, Plzeň, 30614, Czech Republic. Phone: (+420) 777 846 682, Fax: (+420) 377 632 602, Email: pstehlik@kma.zcu.cz.

1. INTRODUCTION

Some economic decisions are more frequent (less rigid) than others. Economic theory has long taken notice of various behavioral rigidities; primarily in attempt to explain some observed macroeconomic phenomena. Empirical research followed and provided convincing micro-level evidence of the rigidity in, among other, price and wage setting.⁴ The presented paper takes rigidity a level up and incorporates it into the timing structure of games.

The motivation is to bridge the gap between the micro-founded models of the economy used in macroeconomics, in which rigidities play a central role, and the rigidity-free solution concepts applied to these very models. This refers to both the repeated game solution and the rational expectations solution – in both it is commonly assumed, explicitly or implicitly, that players move simultaneously and do so flexibly each period.

Both the simultaneity and the flexibility assumptions have however been questioned.⁵ Therefore, we provide an alternative game theoretic framework to consider situations in which players' choices may be infrequent. This is consistent with the concepts of 'economically rational expectations' (Feige and Pearce (1976)) and 'rational inattention' (Sims (2003), Reis (2006)).

It will become apparent that as rigidity ties the hands of the players, it makes the environment more dynamic and asynchronous. As such, it can take the role of *commitment* and help enhance cooperation between players in settings in which inefficient outcomes may otherwise result in equilibrium. In contrast to the standard game theoretic concept of commitment, Stackelberg leadership, that is static, our commitment is dynamic. The desirability of exploring such rigid timing and allowing for more dynamics will be apparent: some of the conventional results on the effect of commitment will be refined and partly qualified.

Our general rigid setup can be summarized by one parameter θ ,

$$(1) \quad 0 \leq \theta_t^i \leq 1,$$

which denotes *the probability that player i cannot move in time t* . The framework can be applied to any model in discrete time, continuous time, as well as time scales.⁶ The specification in (1) nests (i) standard repeated games (in which $\theta_t^i = 0, \forall i, t \in \mathbb{N}$), (ii) alternating move games of Maskin and Tirole (1988) and Lagunoff and Matsui (1997) (in which, $\forall t \in \mathbb{N}, \theta_t^i = \frac{(-1)^t + 1}{2}$ and $\theta_t^j = \frac{(-1)^{t+1} + 1}{2}$), as well as (iii) the popular probabilistic specification of rigidity by Calvo (1983) (in which $\theta_t^i = \theta^i, \forall i, t \in \mathbb{N}$). In this paper we concentrate on (iv) the deterministic discrete rigidity setting of Taylor (1979), in which all players move with a certain *fixed frequency* (see Figure 1 for an example). Formally, $\forall i$

$$\theta_t^i = \begin{cases} 0 & \text{if } t = 1 + (n-1)r^i \text{ where } n, r \in \mathbb{N}, \\ 1 & \text{otherwise.} \end{cases}$$

⁴For recent surveys of empirical evidence see Apel, Friberg and Hallsten (2005) and Bewley (2002) respectively. For the seminal theoretical contributions see eg Fischer (1977), Taylor (1980), Calvo (1983), or Mankiw and Reis (2002).

⁵In terms of simultaneity, Lagunoff and Matsui (1997) argue that '*while the synchronized move is not an unreasonable model of repetition in certain settings, it is not clear why it should necessarily be the benchmark setting...*'. In terms of incorporating some inflexibility, in addition to the above papers see a growing body of literature examines some sort of inertia/stickiness/rigidity in updating/forming expectations (see eg Mankiw and Reis (2002) or Carroll and Slacalek (2006)).

⁶Time scales calculus is a recent generalized mathematical environment which nests both discrete and continuous time as special cases, see eg Bohner and Peterson (2001). For a discussion of our framework in continuous and time scales calculi see Section 6 below.

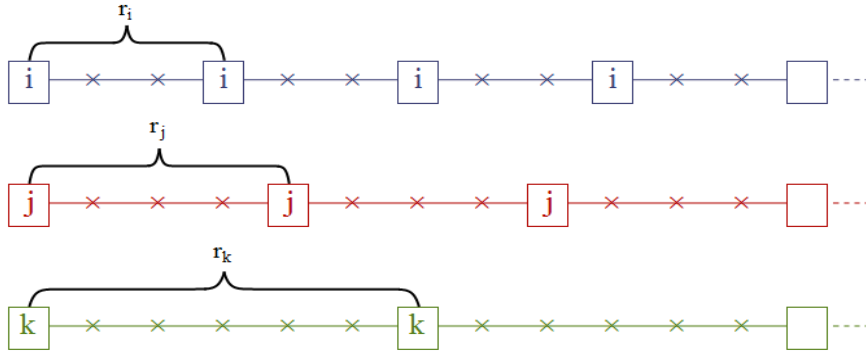

FIGURE 1. Timeline of a rigid (stage) game in discrete time: an example with three players and their rigidities $r^i = 3, r^j = 4, r^k = 6$.

Naturally, we define player i 's **rigidity/commitment**, $r^i \in \mathbb{N}$, to be *the number of periods for which the respective action cannot be reconsidered*.⁷ Let us spell out four main advantages of such a specification.

Generality. Unlike a standard repeated game, our framework enables us to examine:

- (i) concurrent rigidity/commitment of more than one player,
- (ii) various degrees of such rigidity/commitment,
- (iii) endogenous determination of rigidity/commitment as players' optimal choices.

Some of these features (one at a time) have already been examined in games.⁸ This existing work provides a strong justification and motivation for our general approach; for example Cho and Matsui (2005) argue that: *'[a]lthough the alternating move games capture the essence of asynchronous decision making, we need to investigate a more general form of such processes. . .'*

Familiarity. The framework adopts all the main assumptions of a standard repeated game. Most importantly, it starts with a simultaneous move, ie it does not assign one player to be the Stackelberg leader and the other the follower. Further, rigidity/commitment is constant throughout each game, and all past periods' actions are observable (ie games of perfect monitoring).

Realism. Players' rigidity and commitment introduce some asynchrony in the game and make the game more dynamic. The embedded combination of perfect and imperfect information is arguably a good description of many repeated real world interactions. Further, the framework does not rely on the infinite horizon - a unique efficient outcome can often be obtained in a finite game even without reputational considerations. Finally, the framework captures Tobin's (1982) observation quoted above about varying frequency of agents' actions and its endogeneity.

Simplicity. While allowing for the above extensions some general results will be proven that demonstrate the tractability of our framework. In our deterministic setting the game can be

⁷The terms rigidity and commitment can be used interchangeably in our framework. While a game theorist will find it natural to think of commitment (since her interest lies in the *effect* on the game), a macroeconomist may want to use the term that better reflects the particular underlying circumstances (the *source* of infrequent actions). We will follow the latter practice in this paper due to its macroeconomic application.

⁸Feature (i) is investigated in the alternating move games of Maskin and Tirole (1988). In terms of (ii) Wen (2002) examines a first simple step in this direction with $r^i = 2, r^j = 1$. Finally, Bhaskar's (2002) framework, in which leadership is endogenously determined, offers an avenue to incorporate (iii).

solved by subgame perfection making use of a recursive pattern present in the game. Furthermore, the solution is often as simple as that of a one shot game since the most important ‘action’ will occur in the initial simultaneous move.

In terms of our game theoretic contribution, we show that while some insights obtained under the standard static commitment carry over, some are enriched and some differ. Specifically, in the classes of games in which static commitment is an advantage to the committed player (eg in coordination or anti-coordination games), dynamic commitment continues to be advantageous. This is for the same reasons: commitment allows a player to coordinate on its preferred action with the opponent, or if need be force it onto him. As such, both static and dynamic commitment often resolves a coordination problem or a conflict. Nevertheless, under static commitment the Stackelberg leader in these classes of games ensures its preferred outcome regardless of his exact payoffs or discount factor. We will demonstrate that this is no longer the case under dynamic commitment. Most interestingly, if a player is highly impatient then even an infinitely strong commitment is insufficient to ensure his preferred outcomes.

To demonstrate the framework we use one of the most influential macroeconomic games due to Kydland and Prescott (1977) and Barro and Gordon (1983) (referred to as KPBG). It is shown that the famous time-inconsistency result may not be present in the rigid framework under some circumstances. Specifically, we derive the necessary and sufficient degree of long-term monetary policy commitment above which the efficient ‘Ramsey’ outcome of credibly low inflation - that is not a Nash equilibrium in the standard one-shot or repeated game - uniquely obtains in equilibrium of the rigid game. It is further shown that the required degree of commitment is a function of the characteristics of the economy (eg wage rigidity, the slope of the aggregate supply relationship) and the players’ preferences (eg the policymaker’s inflation aversion and discount factor). Interestingly, there exist circumstances under which this degree is arbitrarily low, and others under which it is infinitely high.

Our first policy finding is that monetary commitment, as well as the central banker’s patience and conservatism reduce inflation and its variability (under some - but not all - circumstances). We discuss how these features have been achieved in the real world context drawing a link to the observed trend towards explicit inflation targets (ITs) and central bank independence (CBI). Since an IT is transparently incorporated in the central banking legislation, the target cannot be frequently reconsidered, and the choice of the long-run inflation level is therefore rigid. This provides a *long-run* commitment. In contrast, monetary policy patience have come under the heading of CBI, whereby independent central bankers have been granted a longer term in office, which arguably makes them more patient.

These results therefore offer an explanation for the convergence to low inflation and high credibility in industrial countries over the past two decades - as a consequence of explicit IT and CBI. Note that this explanation is independent of (but compatible with) the three standard remedies of the time-inconsistency problem in the literature, namely (i) the Barro and Gordon (1983) reputation building, (ii) the Rogoff (1985) conservative central banker, and (iii) the Walsh (1995) incentive contract.

Our second policy result then follows: an explicit IT can substitute for goal-CBI in ensuring the credibility of low inflation. This substitutability offers an explanation for the fact that inflation targets have been made more explicit in countries that had lacked central bank goal-independence in the late 1980s such as New Zealand, Canada, UK, Sweden and Australia, rather than those with an independent central bank such as the US, Germany and Switzerland.⁹

⁹For the inflation targeting debate in regards to the Fed, which started well before the global financial crisis, see eg Goodfriend (2003), Kohn (2003), McCallum (2003), Friedman (2004), Mishkin (2004), or Bernanke and Woodford (2005).

The rest of the paper is structured as follows. Section 2 presents a simple KPBG model and its game theoretic representation. Section 3 outlines the deterministic rigid setup. Section 4 reports our results. Section 5 brings empirical evidence for our results, also reconciling some contradictory findings of the existing literature. Section 6 discusses their robustness and a number of extensions. Section 7 summarizes and concludes.

2. THE MONETARY POLICY GAME

To keep our attention on the insights obtained from the rigid framework, we will postulate the simplest reduced-form KPBG model and show how it (or any other model) can be converted into a 2x2 game theoretic representation. This representation will then be used throughout and our results contrasted with conventional game theoretic results.

2.1. Preferences and Constraints. In the KPBG game there are two players, the policymaker g and (homogenous) public p .¹⁰ The players' discount factors are δ_g and δ_p , whereby we will call those with $\delta = 1$ as (fully) patient and those with $\delta < 1$ as impatient. Their period utility functions are the following

$$(2) \quad u_t^g = -(\pi_t - \tilde{\pi})^2 + \alpha y_t,$$

$$(3) \quad u_t^p = -\beta(\pi_t - \pi_t^e)^2 - (\pi_t - w_t)^2,$$

where time $t \in \mathbb{N}$, π denotes inflation, $\tilde{\pi}$ is the optimal inflation level (not necessarily announced publicly), and y denotes the output gap. Further, π_t^e and w denote inflation expectations and wage inflation, both set in a forward looking fashion by a rational public. The positive parameters α and β describe the relative weights between the players' objectives.

The intuition is in line with the rest of the KPBG literature. The policymaker cares about high output and low inflation. The public cares about correctly expecting the inflation rate in order to set its instrument - wages - at the market clearing real wage level, see eg Backus and Driffill (1985). We postulate wage setting separately from expectations setting in order to be able to formally model wage rigidity and its effect on macroeconomic outcomes.

The economy is described by a simple Lucas type supply relationship

$$(4) \quad y_t = \rho(\pi_t - \pi_t^e) + \lambda(\pi_t - w_t),$$

where $\rho > 0$ and $\lambda > 0$ are parameters. This expresses that inflation over and above the level that is expected and/or incorporated into wage contracts will be stimulatory to the economy. It will lead to output above potential because it results in a below equilibrium real wage.

2.2. Long-run Perspective. Since our interest lies in the effect of policy commitment we focus on long-run/average/trend outcomes of the game. To do so, we have made the economy deterministic by disregarding shocks in (4), from which it follows that assuming out the policymaker's aversion to output volatility in (2) is without loss of generality. It also follows that π can be taken directly as the policymaker's instrument, and that it represents choosing *average* inflation or a certain level of a long-run IT.¹¹

¹⁰Our framework allows us to examine any type of heterogeneous agents within the public, which we discuss in Section 6.

¹¹Long-run IT means that the legislated horizon of the target is the business cycle or longer (indefinite) - as is common in industrial countries, see Mishkin and Schmidt-Hebbel (2001). Since shocks have a zero mean, they do not affect the average/trend levels. Therefore, our conclusions would still hold even in the presence of shocks - see the discussion in Section 6. Let us also note that (4) could be equivalently written as an expectations-augmented Phillips curve, in which case the policymaker would be choosing inflation indirectly through the interest rate and output. This is because (i) the two specifications feature the same relationships (in terms of the sign) between actual inflation, expected inflation, and output, and (ii) there is a unique mapping between the interest rate and inflation.

To obtain the equilibrium inflation level in the standard game we use (2)-(4)

$$(5) \quad \pi_t^* = \tilde{\pi} + \frac{\alpha\lambda}{2} = \pi_t^{e*} = w_t^*.$$

The fact that $\pi_t^* > \tilde{\pi}$ yields the famous time-inconsistency and inflation bias results of KPBG. Under a deterministic long-run economy and players' full information, which will be assumed throughout, the public can always perfectly predict the inflation rate, and (5) then implies that it will set $\pi_t^e = \pi_t$ in all t . Nevertheless, we will see below that in the presence of wage rigidity the public may not be able to flexibly re-set wages according to their optimal level, $w_t^* = \pi_t$.

2.3. Game Theoretic Representation. For game theoretic clarity we will follow Cho and Matsui (2005) and restrict the players' action sets to two levels, low (L) and high (H). In its general form the game can be summarized by the payoff matrix in Figure 2, in which the payoffs $\{a, b, c, d, q, v, x, z\}$ are functions of the parameters of the macroeconomic model $\{\alpha, \beta, \rho, \lambda\}$.

		<i>Public</i>	
		L	H
<i>Policymaker</i>	L	a, q	b, v
	H	c, x	d, z

FIGURE 2. A general 2x2 KPBG game

We will refer to $(a - d)$ as the inflation cost, $(c - a)$ as temptation, and $(a - b)$ as the output loss of disinflation or output gain of inflation.¹² As Cho and Matsui (2005), we depict the most natural candidates for L and H - the optimal (but time-inconsistent) level from (2) and the time-consistent (but sub-optimal) level from (5)

$$\pi \in \{L = \tilde{\pi}, H = \tilde{\pi} + \frac{\alpha\lambda}{2}\} \ni w.$$

2.4. General and Specific KPBG Game. Throughout the paper we will use two versions of the game and refer to them as general and specific. The *specific* game will use the payoffs derived from the model to numerically illustrate the results. Using (2)-(4) and dividing through by $(\alpha\lambda/2)^2$ without loss of generality, the KPBG model yields the payoffs reported in Figure 3 and the following equation

$$(6) \quad c = 1 > a = 0 > d = -1 > b = -2 \quad \text{and} \quad q = z = 0 > v = x = -1.$$

In the *general* game payoffs satisfy the following conditions

$$(7) \quad c > a > d > b, q > v, q \geq z > x \quad \text{where} \quad c = a - b + d.$$

The latter equality holds generally in a large class of macroeconomic models since the magnitude of temptation equals the output gain from unexpected inflation minus the associated cost of inflation, that is $c - a = a - b - (a - d)$. Nevertheless, it is not essential for our game theoretic analysis and we only use it to streamline the paper.

¹²In models in which the aggregate supply (Phillips curve) relationship is linear, and policy preferences symmetric with respect to above and below potential output, the policymaker's output gain of unexpected inflation equals the output loss of disinflation.

		<i>Public</i>	
		w^L	w^H
<i>Policymaker</i>	π^L	0, 0	-2, -1
	π^H	1, -1	-1, 0

FIGURE 3. The specific KPBG game payoffs from (2)-(4).

2.5. Stage Game With and Without Standard Stackelberg Commitment. We see from Figure 3 that the inefficient (H, H) outcome is the unique Nash equilibrium of the standard static stage game. In contrast, the efficient and Pareto superior outcome (L, L) is *not* a Nash equilibrium. It therefore follows that in a finite horizon game without some form of reputation the latter cannot be achieved, ie the inflation target is time-inconsistent and lacks credibility.¹³

The standard way to eliminate the time-inconsistency and inflation bias is to impose the policymaker's commitment - Stackelberg leadership. If the policymaker is the Stackelberg leader (first mover in the game), then (L, L) becomes the unique equilibrium outcome. It should be noted that this happens regardless of the exact payoffs and discount factors.

Our aim in the rest of the paper is to examine the robustness of these standard results in the rigid environment. Our analysis in Section 4 shows that allowing for various degrees of rigidity and hence dynamic commitment refines and partly qualifies the standard conclusions.

3. DETERMINISTIC RIGIDITY/COMMITMENT

3.1. Assumptions. As discussed in the introduction, we are interested in rigidity and commitment that are deterministic and constant throughout each game. Due to our macroeconomic application we will consider discrete time, $t \in \mathbb{N}$. In summary:

Definition 1. *An asynchronous game that starts with a simultaneous move of all players i (in period $t = 1$), and continues with their moves every r^i periods, will be referred to as the **rigid game**. Its **stage game** lasts T periods, where $T \in \mathbb{N}$ denotes the 'least common multiple' of all players' r^i .*

For example in Figure 1 we have $T(r^i = 3, r^j = 4, r^k = 6) = 12$. Note that the stage game of the rigid game is also a dynamic game, as opposed to the standard stage game of the simultaneously repeated game that is static - it only lasts one period.

In addition to these timing assumptions, we will focus on the natural starting point in which the players are rational, have common knowledge of rationality, and for expositional clarity also complete information about opponents' payoffs and the structure of the game - including all the rigidities r^i . Further, all past periods' moves can be observed (perfect monitoring).¹⁴

3.2. (Non)-Repetition. The full rigid game can consist of any number of repetitions (finite or infinite) of the rigid stage game. Nevertheless, we will restrict our attention to the rigid stage game itself, since our interest lies in deriving conditions under which a *Pareto-efficient* outcome *uniquely* obtains on its equilibrium path. Under these conditions, repeating the rigid stage game would not affect the derived equilibrium. This is because if the outcome is already

¹³By credibility of low inflation we will mean a situation of π^L accompanied by the L level of both expectations and wages. If either of these has the H level we will talk about 'lack of credibility'.

¹⁴A number of alternative specifications are discussed in Section 6.

unique and Pareto-efficient then we know that the effective minimax values (ie the infima of the players' subgame perfect equilibrium payoffs) of the repeated game will be equivalent to those of the rigid stage game - since these cannot be improved upon. Put differently, the set of Pareto superior payoffs is empty.

There are several advantages of focusing on the efficiency/uniqueness conditions in the rigid stage game. First, the assumption of the public being composed of infinitesimal agents (as in Cho and Matsui (2005)) is not required to avoid the Folk theorem. Second, we can focus on pure strategies without loss of generality. Third, we can think of our results as the worst case scenario, in which repetition does not help the players to cooperate.

3.3. Real World Interpretation. The public is assumed to be able to adjust expectations every period, but due to some cost of wage bargaining the same may not apply to wage setting. We will therefore interpret r^p as *wage rigidity* following Taylor (1979).

In terms of the policymaker, r^g will denote the strength of the monetary policy *long-run commitment*.¹⁵ The variable r^g can also be interpreted as the degree of the inflation target's *explicitness*. This is based on the assumption that the more explicitly the IT is stated in the central banking legislation, the less frequently it can be altered (in the Taylor (1979) deterministic sense) or the less likely it is (in the Calvo (1983) probabilistic sense). Intuitively, legislating the target increases the (political, legal, and credibility) cost of renegotiating/altering the target. This assumption is supported by the fact that (i) there have only been very few occasions of a country changing its legislated IT (and these changes very only trivial), and (ii) to our knowledge, no country has ever abandoned an explicit IT.

As a real world example of deterministic r^g , the 1989 Reserve Bank of New Zealand Act states that the inflation target may only be changed in a Policy Target Agreement (PTA) between the Minister of Finance and the Governor and this can only be done on *pre-specified regular* occasions (eg when a new Governor is appointed).¹⁶

It should further be noted that the absence of a legislated numerical target may not necessarily imply $r^g = 1$; it has been argued that many countries pursue an inflation target implicitly (including the US, see e.g. Goodfriend (2003), or the Bundesbank and the Swiss National Bank in the 1980-90s, see Bernanke, et al. (1999)). In such cases we have $r^g > 1$, but r^g is smaller than under a fully-fledged legislated IT.

3.4. Notation. We denote player i 's moves by n^i , and the number of his moves in the rigid stage game by N^i . It then follows that $N^i = \frac{T(r^g, r^p)}{r^i}$. Also, g_n^l and p_n^l will denote a certain action $l \in \{L, H\}$ in a certain node n^i , eg p_2^H refers to the public's high wage play in its second move. For notational parsimony, we will introduce the notation for the case of interest, $r^g \geq r^p$. Denote $\frac{r^g}{r^p} \geq 1$ to be the players' *relative rigidity*. Then $\lfloor \frac{r^g}{r^p} \rfloor \in \mathbb{N}$ is the integer value of relative rigidity (the floor), and $R = \frac{r^g}{r^p} - \lfloor \frac{r^g}{r^p} \rfloor = [0, 1)$ denotes the fractional value of relative rigidity (the remainder).¹⁷

Further, we denote $b(\cdot)$ to be the best response. For example, $g_1^L \in b(p_1^L)$ expresses that π^L is the policymaker's static best response to the public's initial w^L move, and $\{g_1^L\} = b(p_1^L)$

¹⁵It should be stressed that due to the long-run perspective r^g does *not* relate to the frequency with which the short-run policy instrument, the interest rate, can be adjusted. As long as the underlying (unmodelled) setting of the interest rate is on average consistent with the selected long-run inflation target - which we implicitly assume - the frequency of monetary policy committee meetings plays no role in determining long-term outcomes, only variability around the trend.

¹⁶Since late 1990 the PTA was 'renegotiated' five times, ie roughly every three years. Only on two occasions the target level was changed: in 1996 from 0-2% to 0-3% and in 2002 to 1-3%.

¹⁷It will be evident that R plays an important role since it determines the exact type of dynamics (asynchrony) in the game.

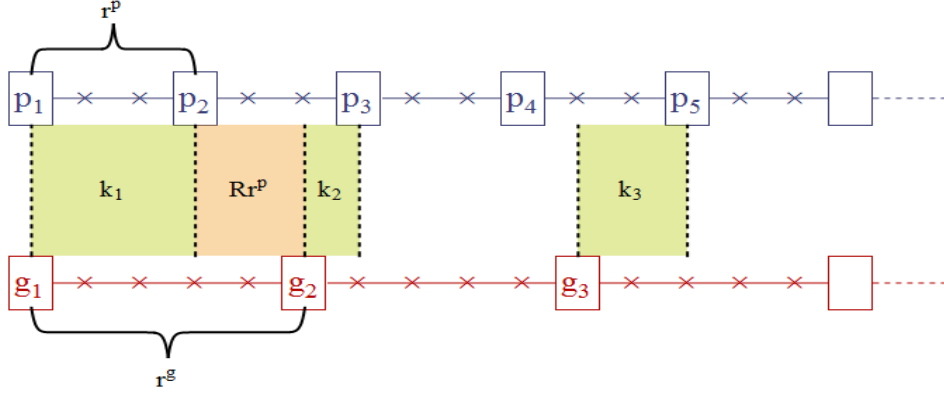

FIGURE 4. The rigid stage game - an example of timing of moves with $r^g = 5$ and $r^p = 3$, illustrating the variables k_n, n^i , and R .

expresses that it is the unique best response. Alternatively, to indicate a unique best response to the opponent's current play (without specifying the exact node), the latter will be written as $\{g_1^L\} = b(w^L)$. An asterisk will denote optimal play, ie $p_1^* \in b(g_1)$ expresses that the public's optimal first move is the best response to the policymaker's first move. Finally, threshold levels will be denoted by either upper or lower bar.

3.5. Recursive Scheme. The fact that we can report some general results that obtain for any rigidities r^i and any degree of asynchrony R is owed to the recursive scheme implied by our setup and number theory. Let us use k_n to denote the number of periods between the n^g -th move of the policymaker and the immediately following move of the public. This implies, for our case of interest $r^g \geq r^p$, that $k_1 = r^p$ (see an example in Figure 4).

From this it follows that the number of periods between the $(n^g + 1)$ -th move of the policymaker and the immediately preceding move of the public equals $r^p - k_{n+1}$. Using these, we can summarize the recursive scheme of the game as follows:

$$(8) \quad k_{n+1} = \begin{cases} k_n - Rr^p & \text{if } k_n \geq Rr^p, \\ k_n + (1 - R)r^p & \text{if } k_n < Rr^p, \end{cases}$$

Generally, k_n is not a monotone sequence, see Figure 4.

3.6. History and Future. By convention, history in period t , h_t , is the sequence of actions selected prior to period t , and future in period t is the sequence of current and future actions. It follows from our perfect monitoring assumption that h_t is common knowledge at all t . We will refer to moves i_n^l , in which a player's optimal play is to choose a certain action $l^* \in \{L, H\}$ for any history h_t , as 'history-independent'.

3.7. Strategies and Equilibria. A strategy for a certain player is a function that, $\forall h_t, t$, assigns a probability distribution to the player's action space. A strategy of player i is then a vector that, $\forall h_t$, specifies the player's play $\forall n^i$.

The rigid game will commonly have multiple Nash equilibria. To select among these we will use a standard equilibrium refinement, subgame perfection, that eliminates non-credible threats.

Subgame perfect Nash equilibrium (SPNE) is a strategy vector (one strategy for each player) that forms a Nash equilibrium after any history h_t .¹⁸

Given the large number of nodes in the game, reporting fully characterized SPNE would be cumbersome. We will therefore focus on the *equilibrium path* of the SPNE, ie actions that will actually get played.¹⁹ To simplify the language let us define the following.

Definition 2. Any SPNE, in which all players play L in all their moves on the equilibrium path, $i_n^{L^*}, \forall n, i$, will be called a **Ramsey SPNE**.

4. RESULTS

Our aim is to revisit the standard results with and without Stackelberg commitment (reported in Section 2.5), allowing for the rigid environment and dynamic commitment. This section shows that they are refined and partly qualified. First, we show that the efficient Ramsey outcome, in which both players play L throughout, can be uniquely achieved: (i) in a finite game, (ii) even without assuming the policymaker's first move, and (iii) without reputational considerations. Second, we derive the exact degree of commitment that ensures this and show it to be a function of various characteristics of the economy and the players' preferences. Third, and perhaps surprisingly, it is demonstrated that under some circumstances the required commitment is arbitrarily low, and under others even an infinitely strong commitment is insufficient. This is in contrast to the intuition of the standard Stackelberg commitment concept, whereby policy commitment guarantees (L, L) under all circumstances - irrespective of the exact payoffs and discount factors.

To better expose the solution and intuition of the rigid environment: (i) We complement the results of the general KPBG game in which only (7) is required to hold, with those of the specific KPBG game, in which (6) is also satisfied. (ii) We first focus on the game under patient players, $\delta_p = \delta_g = 1$, and only then extend the findings under players' impatience (where we separate the effects of the public's and the policymaker's discounting by examining them in turns). As the intuition of the rigid environment is independent of the players' discount factor, most of the results will carry over. It will be shown that while the public's impatience improves cooperation, the policymaker's impatience has the opposite effect.

4.1. Patient Players. Let us now report the necessary and sufficient condition for the efficient Ramsey outcome to uniquely obtain.

Proposition 1. Consider the general rigid stage game in which (7) holds, and assume patient players, $\delta_p = \delta_g = 1$. Any SPNE of the game is Ramsey if and only if

$$(9) \quad r^g > \bar{r}^g(R) = \begin{cases} \frac{c-d}{a-d} r^p = \frac{a-b}{a-d} r^p & \text{if } R = 0, \\ \frac{(1+R)(c-d)}{a-d} r^p = \frac{a-b+R(c-d)}{a-d} r^p & \text{if } R \in (0, \bar{R}), \\ \min \left\{ \frac{c-d-(1-R)(a-b)}{a-d} r^p = \frac{a-b}{a-d} R r^p, r^p \right\} & \text{if } R \in [\bar{R}, 1), \end{cases}$$

¹⁸Note that the specification of the players' utility implies that all our SPNE will also be Markov perfect equilibria, for details see eg Maskin and Tirole (2001).

¹⁹To demonstrate, for our example in Figure 4 with $r^g = 5, r^p = 3$, each SPNE consists of $\sum_{s=1}^{r^p} \sum_{f=1}^{r^g} 2^{(s+f-1)} = 254$ actions, whereas on its equilibrium paths there are $r^p + r^g = 8$ actions.

where $\bar{R} = \frac{q-v}{z-x+q-v}$. In the specific KPBG game, in which (6) holds, this happens if and only if

$$(10) \quad \frac{r^g}{r^p} \in \left(\frac{3}{2}, 2\right) \cup \left(\frac{5}{2}, \infty\right).$$

The necessary and sufficient threshold commitment level $\bar{r}^g(R)$ in (9) is, $\forall R$, increasing in wage rigidity, temptation, the disinflation cost, and decreasing in the inflation cost.

Proof. To prove the claims it suffices to show that under the stated circumstances π^L is the policymaker's unique best play in all his nodes for all histories h_t , ie every optimal move g_n^* is 'history independent'. Then the policymaker no longer has an incentive to play π^H . As the public's unique best response to L is L , this will ensure low inflation expectations and hence w^L throughout the equilibrium path.

We solve the game backwards and prove the statements by a mathematical induction argument with respect to the policymaker's moves, focusing on the relevant case $r^g > r^p$. First, we prove that on the equilibrium path L will be played in the policymaker's last move $n^g = N^g$ (the *inductive basis*). Then, supposing that it holds for some $n^g \leq N^g$, we show that the same is true for $(n^g - 1)$ as well (the *inductive step*). This will demonstrate that on the equilibrium path we uniquely have $i_n^L, \forall i, n$, ie only Ramsey type SPNE exist.²⁰ For details of the proof see Appendix A. \square

Let us discuss the intuition of the proofs and results using the special case of $R = 0$: for example $r^g = 2, r^p = 1$. The policymaker has only one move in the rigid stage game, whereas the public has two moves. Solving backwards, the policymaker knows that in its second move the public will play the static best response to the policymaker's initial move, which is L to L , and H to H .

Taking this into account, the policymaker's considered options are the following. He plays H and possibly gets a boost in output and his preferred payoff c . But this would only last for r^p periods, after which the public would play H (regardless of its initial move) and 'punished' the policymaker for inflating.²¹ We can think of this scenario as a (possible) short-run gain versus a (sure) long-run loss. As an alternative option, the policymaker plays L and possibly gets an inferior off-diagonal payoff b initially. In such case however, the public would play L in its second move and 'reward' the policymaker for not inflating. We can think of this strategy as a (possible) short-run loss versus a (sure) long-run gain.

Whichever option the policymaker chooses depends on the relative lengths of the gain vs loss, as well as on their relative magnitude.²² The latter is determined by the payoffs $\{a, b, c, d\}$ which are functions of the parameters of the underlying macroeconomic model $\{\alpha, \beta, \rho, \lambda\}$, and hence of the structure of the economy and the policymaker's preferences. In the real world payoffs arguably depend on various other factors we do not model such as political economy factors (lobby groups, political cycles, Union power) or institutional setting of monetary and fiscal policy. In contrast, the length of the gain or loss is determined by policy commitment. For all SPNE to be Ramsey, it is required that the policymaker is sufficiently committed given its

²⁰It will become evident that for most parameter values satisfying (9) and (10) there will be a *unique* Ramsey SPNE, but since our attention will be on the equilibrium path we will not examine the exact number of Ramsey SPNE (off-equilibrium path behaviour) in detail.

²¹Let us note that unlike in the Barro-Gordon simultaneously repeated game, the public's punishment in the rigid world is not an arbitrary trigger strategy - it is the public's optimal play, and its length is uniquely determined by wage rigidity r^p and policy commitment r^g .

²²Naturally, it also depends on the policymaker's degree of discounting, which is considered in the next section.

temptation. He then finds it optimal to play L under both p_1^L and p_1^H , ie even if he knew with certainty that a short-term loss would occur.²³

It is important to realize that the result of Proposition 1 refines the conclusion made under the standard static commitment concept - in two respects. First, in the standard framework the Stackelberg leader ensures (L, L) regardless of the exact payoffs, and hence independently of the above real world factors. This is not very useful as it does not provide any policy recommendations or predictions that could be tested in the data. Second, even if the policymaker is somewhat committed, it may still not be sufficient to achieve the Ramsey outcome. He needs to be sufficiently strongly committed, $r^g > \bar{r}^g(R)$.

In terms of the latter point it is illustrative to consider why the low commitment values not satisfying (9), $r^g < \bar{r}^g(R)$, fail to deliver Ramsey SPNE. It is because the relative length of the public's punishment is insufficient to discourage the policymaker from inflating. For example, consider the specific game and the values $r^g = 4, r^p = 3$. By backwards induction, it is easy to verify that on the equilibrium path of any SPNE we have $(p_1^{H*}, g_1^{H*}, p_2^{L*}, g_2^{L*}, p_3^{L*}, g_3^{L*}, p_4^{L*})$, where the nodes are ordered as they appear in time. This implies that there would be no punishment whatsoever. The forward looking public knows that the policymaker will optimally reduce inflation from H played in his first move, g_1^{H*} , to L in his second move (ie in period 5, g_2^{L*}). Therefore, the public preemptively plays L even before this disinflation is implemented - in its second move (ie in period 4, p_2^{L*}). The public finds it optimal because its next opportunity for doing so and aligning its play with the policymaker's would only be in its third move (ie in period 7).²⁴

It is apparent that the same applies to the $r^g < r^p$ cases, whereby the policy commitment is insufficient for any general payoffs. For example, under $r^g = 4, r^p = 5$ the equilibrium path of all SPNE is $(p_1^{H*}, g_1^{H*}, p_2^{L*}, g_2^{L*}, p_3^{H*}, p_4^{H*}, g_3^{H*}, p_5^{H*})$, ie both players play H with the exception of their second moves.

4.2. The Public's Impatience. This section shows that the public's discounting may weaken the above conditions for Ramsey SPNE and hence *improve* cooperation. Intuitively, this is because an impatient public ignores disinflations in the near-future and hence more vigorously punishes inflating.

The following result is a general finding that applies to several other classes of games as well - under some circumstances an arbitrary amount of (relative) commitment is sufficient to uniquely achieve an efficient outcome.

Theorem 1. *Consider the general rigid stage game in which (7) holds; and assume a patient policymaker, $\delta_g = 1$, a sufficiently impatient public, $0 \leq \delta_p \leq \bar{\delta}_p < 1$ where $\bar{\delta}_p$ is some upper bound, and a sufficiently high inflation cost, $a - d > \frac{a-b}{2} = \frac{c-d}{2}$. Then for all*

$$\frac{r^g}{r^p} \in (1, \infty),$$

any SPNE of the game is Ramsey.

Proof. See Appendix B. □

²³For this reason each row of (9) has two conditions: one under the public playing p_1^L and the other under p_1^H . Under the general constraints from (7) the conditions are equivalent. If $c \neq a - b + d$ then the necessary and sufficient condition is simply the stronger of each pair of these conditions.

²⁴It is shown in the next section that this pre-emptive behaviour disappears if the public is sufficiently impatient.

Intuitively, an impatient public will disregard the future and always play $w_t^* \in b(\pi_t)$.²⁵ Therefore, it will never reduce wages before the start of the disinflation, ie always punish inflating and make the disinflation costly. As this decreases the policymaker's temptation to inflate, it reduces the degree of required policy commitment. Theorem 1 therefore implies that the public's 'myopic' behaviour of the tit-for-tat variety may be optimal in the rigid world (both for the public and the policymaker) - serving as a credible threat.

We explicitly formulate this result since it shows that credibly low inflation can under some circumstances uniquely obtain in equilibrium in a game theoretic setting that 'approaches' the KPBG repeated game. The required degree of relative commitment may be arbitrarily low, and *any* $r^g > r^p$ is sufficient to ensure the efficient outcome. The next section however shows that this conclusion may change if the policymaker is impatient.

4.3. The Policymaker's Impatience. In this section we demonstrate that the policymaker's discounting of the future *worsens* coordination as it increases the required policy commitment threshold $\bar{r}^g(R)$. The section starts with a result that extends the finding of Lemma 1 under the policymaker's impatience, and greatly simplifies the solution of the game. Its applicability extends to some other classes of games.

Theorem 2. *Consider the general rigid stage game in which (7) holds. If $\{g_1^L\} = b(p_1^L) = b(p_1^H)$ then $\forall n, \{g_n^L\} = b(w^L) = b(w^H)$. Therefore, the former condition regarding the initial simultaneous move is, $\forall R$, sufficient to uniquely ensure Ramsey SPNE in the rigid stage game.*

Proof. See Appendix C. □

Since the initial simultaneous move condition, $n^g = 1$, is the strongest (in a weak sense), it suffices to examine it *assuming* that all further relevant conditions for any $n^g > 1$ hold.²⁶ This is true for any type of dynamics and asynchrony R . This property is very convenient as it significantly reduces the number of steps required to solve the rigid game.

While we can derive the necessary and sufficient commitment threshold $\bar{r}^g(R)$ under impatience - analogous to Proposition 1 under patience, we find it more illustrative to report two existence results that enrich our understanding of the effect of commitment.

Theorem 3. *Consider the general rigid stage game in which (7) holds.*

(i) *If the policymaker is sufficiently patient,*

$$(11) \quad \delta_g > \underline{\delta}_g = r^p \sqrt{1 - \frac{a-d}{c-b}} \stackrel{(6)}{=} r^p \sqrt{\frac{2}{3}},$$

then there exists a sufficient threshold $\bar{r}^g \in \mathbb{N}$, such that $\forall r^g > \bar{r}^g$ and $\{r^p, R, \delta_p, a, b, c, d, q, v, x, z\}$, any SPNE of the game is Ramsey.²⁷

(ii) *If the policymaker is sufficiently impatient,*

$$(12) \quad \delta_g < \underline{\delta}_g = r^p \sqrt{\frac{d-b}{a-b}} \stackrel{(6)}{=} r^p \sqrt{\frac{1}{2}},$$

²⁵Note that since in all but the initial move the players never move simultaneously, this implies $p_{n>1}^* \in b(\pi_{t-1})$, which is observationally equivalent to backward looking expectations.

²⁶Specifically, using k_1 and k_2 with (17), (22), and (24) implies that anything that happens in periods $t > r^g + r^p(1-R)$ can be 'skipped'.

²⁷The left hand side of the $\stackrel{(6)}{=}$ notation will throughout report the outcomes of the general game, and the right hand side of the specific game in which (6) holds. Claim (i) implies that the bound \bar{r}^g depends on δ_g . But for the sake of expositional clarity we use \bar{r}^g instead of $\bar{r}^g(\delta_g)$ (and similarly for all thresholds in the rest of this section). This also implies that the conditions $r^g > \bar{r}^g$ and $\delta_g > \underline{\delta}_g$ are not sufficient for the uniqueness of Ramsey SPNE individually - they have to hold jointly.

then for all $\{R, \delta_p, a, b, c, d, q, v, x, z\}$ even an infinitely strong commitment, $r^g \rightarrow \infty$, does not deliver any Ramsey SPNE.

Proof. See Appendix D. \square

The effect of impatience in the rigid framework is similar to the intuition of repeated games, in which a punishment for defection is determined by the discount factor of the deviating player. In both cases it is harder to deter an impatient player from defecting. However, claim (ii) qualifies the intuition of the standard commitment concept in which Stackelberg leadership of the policymaker uniquely ensures (L, L) for all δ_g - in the rigid environment this is no longer the case.

Equation (9) demonstrated that the special case $R = 0$ is representative of the more asynchronous cases since the thresholds $\bar{r}^g(R)$ for $R = (0, 1)$ do not differ qualitatively from $\bar{r}^g(0)$. Therefore, to streamline the analysis we will investigate below the policymaker's impatience under $R = 0$ and extend our conclusions for all R .

Proposition 2. *Consider the general rigid stage game in which (7) holds, and assume $R = 0$ and $\delta_g > \bar{\delta}_g(0)$. Then the necessary and sufficient threshold $\bar{r}^g(0)$ is increasing in wage rigidity, temptation, the disinflation cost, and decreasing in the inflation cost and the policymaker's discount factor, δ_g . The latter negative relationship implies that the policymaker's commitment and patience are substitutes in achieving the Ramsey SPNE.*

Proof. Appendix E shows that the necessary and sufficient commitment level is

$$(13) \quad r^g > \bar{r}^g(0) = \log_{\delta_g} \left(\frac{(a-b)\delta_g^{r^p} - d + b}{a-d} \right) = \log_{\delta_g} \left(\frac{(c-d)\delta_g^{r^p} - c + a}{a-d} \right) \stackrel{(6)}{=} \log_{\delta_g} (2\delta_g^{r^p} - 1),$$

from which the implied necessary and sufficient patience threshold is

$$(14) \quad \delta_g > \bar{\delta}_g(0) = \sqrt[r^p]{\frac{d-b}{a-b}} = \sqrt[r^p]{\frac{c-a}{c-d}} \stackrel{(6)}{=} \sqrt[r^p]{\frac{1}{2}}.$$

It is straightforward to see that both arguments of the logarithm in (13) are increasing in d and decreasing in a , the former is further decreasing in b and the latter increasing in c , which proves the claims about the effect of $\{c-a, d-b, a-d\}$. To prove the remaining two claims on the negative relationships of $\bar{r}^g(0)$ with r^p and with δ_g , further steps are required. For formal proofs see Appendix E, for a graphical demonstration of these relationships see Figure 5. \square

The proposition implies that the intuition of the patient policymaker environment is unchanged; $\bar{r}^g(R)$ under patience and impatience is a function of the same variables with the same signs (compare Propositions 1 and 2). Further, while \bar{r}^g does not exist $\forall \delta_g$, it exists for a wide range of δ_g values so it can still be concluded that the results are fairly robust to the policymaker's discounting.²⁸

For quite some time (well preceding the global financial crisis) there has been a heated debate about the effects of monetary policy commitment, and explicit IT in particular (which we discuss in Section 5 below). The inverse relationships of \bar{r}^g with δ_g means that a less patient policymaker needs to commit more strongly (make its inflation target more explicit) to ensure credibility. The following Corollary - directly implied by Proposition 1 and Theorem 3 - summarizes the adverse consequences of insufficient monetary policy commitment, $r^g < \bar{r}^g(R)$, and provides further testable hypotheses that contribute to this debate.

²⁸For example, Figure 5 shows the following for the specific game in (6). If for instance $r^p = 1$ (which implies $R = 0, \forall r^g$) then under $\delta_g = 1$ we have $r^g > \bar{r}^g(0) = 2$ (from (9)), under $\delta_g = 0.99$ we have $r^g > \bar{r}^g(0) \approx 2.01$, under $\delta_g = 0.8$ we have $r^g > \bar{r}^g(0) \approx 2.29$, and under $\delta_g = 0.51$ we have $r^g > \bar{r}^g(0) \approx 5.81$ (all from (13)).

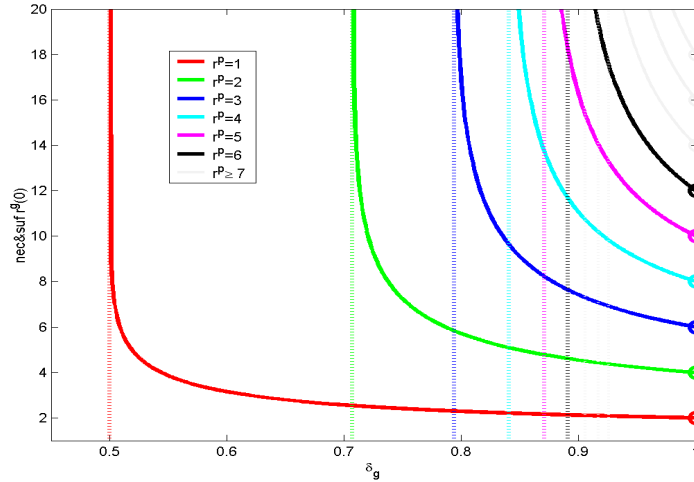

FIGURE 5. Dependence of $\overline{r^g}(0)$ on r^p and δ_g (from (13) and (14) for the specific game (6)). The dotted asymptotes show the $\overline{\delta_g}(0)$ thresholds.

Proposition 3. Consider the general rigid stage game in which (7) holds.

(i) If $r^g \in [1, \overline{r^g}(R))$ then the optimal inflation level is time-inconsistent (lacks credibility) and therefore the average level of inflation is higher than under $r^g > \overline{r^g}(R)$.

(ii) If $r^g \in (\underline{r^g}(R), \overline{r^g}(R))$, where $R = (0, 1)$ and $\underline{r^g}(R)$ is some lower bound, then inflation variability is higher than under $r^g > \overline{r^g}(R)$.

Intuitively, if $r^g > \overline{r^g}(R)$ then the optimal π^L level of inflation obtains uniquely on the equilibrium path, ie average inflation is always on target and hence its variability is zero. In contrast, if $r^g < \overline{r^g}(R)$ then the level π^H obtains on the equilibrium path for at least one n^g , and this increases average inflation as claimed in (i). For this to also increase the variability of inflation, an additional condition is required ensuring that the level π^H does not obtain for all n^g , ie that both π^L and π^H occur in equilibrium. This is ensured by $r^g > \underline{r^g}(R)$. Let us stress that, unlike in the KPBG model, the variability result obtains even in the absence of shocks, ie for *trend/long-run* inflation. This arises because the gains and costs of inflating vary in time with k_n .

5. EMPIRICAL EVIDENCE

Our analysis has several testable implications. The long-run level of inflation and its variability are shown to be weakly decreasing (and hence the policy's credibility increasing) in the degree of the policymaker's: (i) long-run commitment, r^g , (ii) patience, δ_g , and (iii) conservatism, α , (implied by (5) in the spirit of Rogoff (1985)). Further and interestingly, our model implies a negative relationship between patience/conservatism on one hand and commitment on the other due to their substitutability (Proposition 2).

It should however be stressed that all these results obtain weakly, ie only under the circumstances we reported, whereas under others there may be no relationship between these variables.

This qualification is crucial in terms of empirical testing as it should guide the choice of the sample and control variables.²⁹

We will first discuss suitable proxies of these variables, then examine the patience-commitment relationship, and then revisit their effect on inflation and its variability. In doing so, some conflicting empirical findings of the literature will be reconciled based on our theoretical results.

5.1. Proxies. The policymaker's (long-run) commitment was interpreted in Section 3.3 as the degree of explicitness of the IT. While there exist no index that would measure the target's explicitness, the closest proxies are arguably the pivotal features of the regime, namely the degrees of (goal) transparency and accountability (see eg Bernanke et al (1999)).

In terms of patience and conservatism it can be argued that they are a function of several characteristics of monetary policy, most importantly the degree of central bank goal-independence (goal-CBI). First, goal-independent central bankers have a longer term in office which is likely to translate into more patient behaviour (see eg Eggertsson and Le Borgne (2003)). Second, they are commonly more conservative (tougher on inflation) in the spirit of Rogoff (1985). In the past two decades the real world has seen a move in the direction of increasing goal-CBI, and greater length of the banker's term has come as one of the arrangements (see for example Waller and Walsh (1996)).³⁰

5.2. Institutional Relationships: IT vs Goal-CBI. Using these proxies implies that there exists substitutability between explicit inflation targeting and goal-CBI in ensuring low inflation and high credibility. This novel prediction is supported by several studies that report a negative correlation between (goal) CBI and accountability, eg Briault, Haldane and King (1997), de Haan, Amtenbrink and Eijffinger (1999), and Sousa (2001) (see Figure 6 for an example, which can be directly related to Figure 5). Note that virtually all top left hand corner countries have an explicit IT.

Despite the arguable shortcomings of any such index, this finding seems robust as it has been obtained using differently constructed indices for different countries and periods. If we plot Sousa (2001) final responsibility against the length of term in office (which is one of the criteria in his CBI index) the picture remains roughly the same. Furthermore, in a comprehensive data set of Fry et al. (2000) the length of term in office is negatively correlated to accountability procedures (that apply when targets are missed or must be changed) in both industrial and transition countries. Finally, transparency, too, seems negatively related to goal-CBI; for example, the correlation between transparency in Eijffinger and Geraats (2006) and goal-CBI in Briault, Haldane and King (1997) is -0.86 (with the t -value equaling -4.46).³¹

²⁹For example, our results are *not* equivalent to the claim that IT countries will have lower (level and variability of) inflation than non-IT countries, since they obtain only under some (not all) circumstances. Unfortunately, this is the hypothesis most of the literature has tested using a dummy variable for IT. We are not the first paper to point out a problem this approach, see eg Gertler (2003).

³⁰On the length in office for 93 countries see Mahadeva and Sterne (2000), Table 4.4. While the norm of 5-7 years is only marginally longer than the government's term, in the majority of cases in industrial countries the Governor gets reappointed which makes the expected term in office significantly longer. The U.S. offers itself as a good example.

³¹It should be mentioned that this finding does not seem to be a result of omitted variables: economic theory does not identify any other reasons for this negative relationship. In fact, the conventional view that accountability and transparency should go hand in hand with independence to be consistent with democracy (for a widely cited example see King (1998)) implies that the correlation should be *positive*. The Debelle and Fischer (1994) distinction between goal and instrument CBI is however crucial. Instrument-CBI has come as a part of IT (as one of the prerequisites of the regime so its correlation with transparency and accountability in most indices is positive, see eg Chortareas, Stasavage and Sterne (2002)). Our paper makes predictions about goal-CBI as both α and δ_g relate to the parameters in the policymaker's objective function.

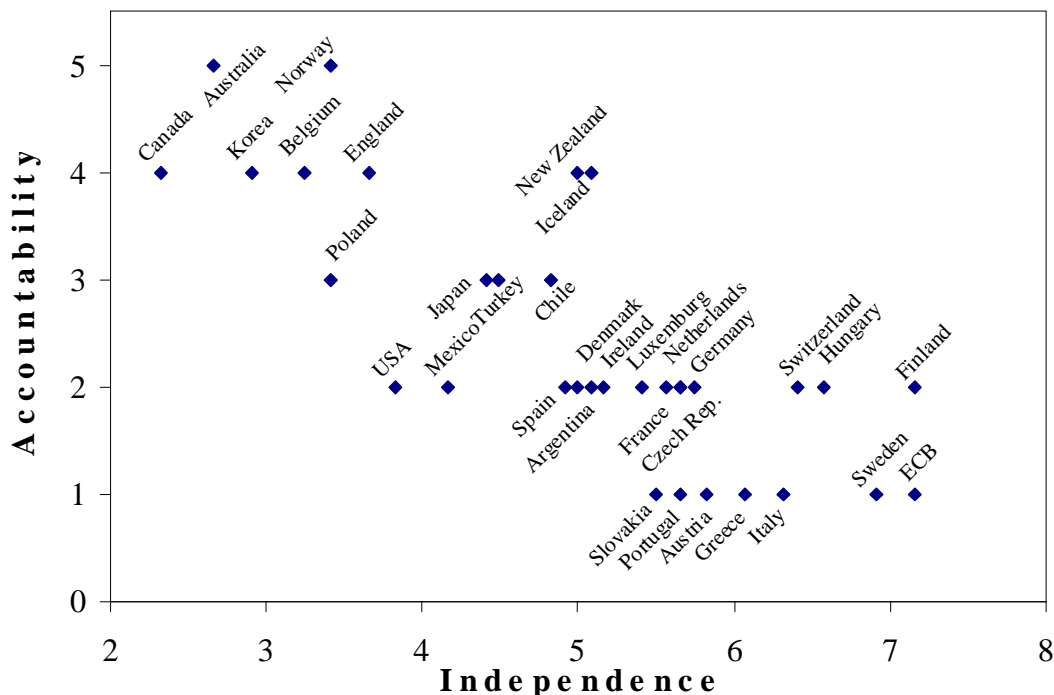

FIGURE 6. Central bank accountability vs independence, Sousa (2001). We use the ‘final responsibility’ component of accountability, see his paper for details on the criteria, countries, and scores. The correlation coefficient equals -0.78 (the t -value equals 6.94).

5.3. Effect of IT and CBI on Inflation. The empirical literature can be divided into two broad categories. Papers that only include industrial countries and only data from mid/late 1980s onwards find weak and/or insignificant effects of inflation targeting on inflation and its volatility, eg Ball and Sheridan (2003) and Willard (2006). In contrast, papers with larger samples that also include developing/transition countries and/or longer time series find strong and significant effects of explicit IT, see eg Corbo, Landerretche and Schmidt-Hebbel (2001).

Our results shed light on these conflicting findings. They imply that a more explicit long-run IT reduces the level of inflation and its variability, but only under some circumstances. Specifically, one necessary condition reported in Corollary 3 is that the initial level of explicitness is insufficient to achieve the Ramsey SPNE, $r^g < \overline{r^g}(R)$. This condition is likely to be satisfied for most industrial countries during the last two decades, which explains the former set of results. In contrast, the condition does not seem to hold in those countries in the 1970s, and in most developing/transition economies even more recently. This is consistent with the latter category of papers.

Furthermore, in line with the predictions of our model, inflation has been found negatively correlated with accountability (Briault, Haldane and King (1997)) as well as with transparency (Chortareas, Stasavage and Sterne (2002) and Fry et al. (2000)). See also Debelle (1997) who

finds inflation targeting to increase the policy's credibility. All these papers include pre-1980 inflation data and/or developing countries. In contrast, papers that only focus on industrial countries and use post-1980 data often find no correlation, see eg Eijffinger and Geraats (2006).

Similarly, goal-CBI was found to be associated with lower inflation, see Grilli, Masciandaro and Tabellini (1991) or Eijffinger, Schaling and Hoeberichts (1998). However, using more recent data inflation is uncorrelated to goal-CBI among industrial countries, see eg Fry et al. (2000).

6. ROBUSTNESS AND EXTENSIONS

This section discusses some extensions and implies that our results are robust to a number of alternative specifications and assumptions.

6.1. Game Theoretic Issues. Other Classes of Games. Our results imply conditions analogous to (9) and (13) for other classes of games. Generally speaking, allowing for varying degrees of commitment/rigidity may help alleviate inefficiency and assist equilibrium selection. It may therefore make a difference in games in which standard commitment alters the set of equilibrium outcomes such as coordination and anti-coordination games (eg the Battle of the Sexes, Stag Hunt, the Game of Chicken etc). For example the former game can be summarized by the following constraints

$$a > c, a > d > b \text{ and } z > y, z > v > w.$$

While this game has two pure (and one mixed) strategy equilibria in the standard one-shot game, in the rigid framework an efficient outcome can be *uniquely* selected. The analog of (9) that achieves all SPNE to be Ramsey is

$$\frac{r^g}{r^p} > \frac{\bar{r}^g(R)}{r^p} = \begin{cases} \frac{a-b}{a-d} & \text{if } R = 0, \\ \frac{a-b}{a-d} + R & \text{if } R \in (0, \bar{R}), \\ \frac{a-b}{a-d} R & \text{if } R \in [\bar{R}, 1), \end{cases} \quad \text{where } \bar{R} = \frac{v-w}{z-y+v-w}.$$

Naturally, our dynamic commitment will not improve equilibrium outcomes in games such as the Prisoner's dilemma in which the inefficient outcome is a result of both players playing a strictly dominant strategy.

Endogenous r^i . It should be noted that all r^i 's can be endogenized as players' optimal choices. As suggested by Tobin (1982) in the opening quote this seems desirable - while rigidity has been found important, most common macroeconomic models take it as exogenously given.³² Libich (2010) is a step in this direction - it formalizes the concept of 'economically rational expectations' (Feige and Pearce (1976)) by incorporating various realistic costs into the players' objectives (that are some function of r^i) and letting them choose their r^i 's optimally at the beginning of the game. In terms of the public, it postulates a wage bargaining cost and a cost of updating expectations (processing information) about macroeconomic shocks. In terms of the policymaker, a cost of explicit commitment is considered (such as implementation or accountability cost).

Probabilistic r^i . Deterministic rigidity/commitment of Taylor (1979) can be reinterpreted as a probabilistic one in the spirit of Calvo (1983), in which $\theta_t^i = \theta^i, \forall i, t \in \mathbb{N}$. In such case the average/expected length of time between each move is $\frac{1}{1-\theta^i}$, which is equivalent to our deterministic r^i . Therefore, the intuition would remain the same, ie under a sufficiently committed and patient policymaker, $\theta^g > \bar{\theta}^g$ and $\delta_g > \bar{\delta}_g$, the Ramsey SPNE would uniquely obtain.

More Players - eg Heterogeneous Public. The number of players can easily be increased - for example, we can model heterogeneous public whose members do not bargain wages collectively. The players' set is then $I = \{g, p^j\}$, where $j \in [1, J]$ denotes a certain Union (individual)

³²Hahn (2006) is one of the notable exceptions in endogenizing price rigidity in the New Keynesian framework. Further, Bhaskar (2002) proposed an alternative way to endogenize the timing of games.

with wage rigidity of r_j^p , and relative size P_j such that $\sum_1^J P_j = 1$. The necessary and sufficient condition analogous to the first row of (9) then generalizes from $r^g(0) > 2r^p$ to

$$(15) \quad r^g(0) > 2 \sum_{j=1}^J P_j r_j^p.$$

This demonstrates that the nature of the results remains unchanged.

Continuous Action Space. Allowing the players' actions to be continuous has the natural consequence of increasing $\bar{r}^g(R)$ compared to the above analysis. This is intuitive; if the policymaker can engage in arbitrarily small inflation surprises his temptation to do so increases, the public's punishment decreases, and hence a stronger commitment is required. Despite this quantitative difference, all our findings carry over qualitatively.

Continuous Time, Time Scales, and Time-Varying r^i . Both continuous and discrete models can be illustratively generalized using time scales - a recent mathematical tool, see eg Bohner and Peterson (2001) for a comprehensive treatment. A *time scale* \mathbb{T} is defined as a nonempty closed subset of the real numbers \mathbb{R} . In the analysis, the so-called 'jump operators' play a key role.

The main contribution of this environment is the ability to consider *non-constant* (heterogeneous) rigidity/commitment. This generalization is arguably realistic and hence important in many settings in economics, econometrics, as well as other disciplines.³³ The analysis in Libich and Stehlík (2008) implies that the condition analogous to $r^g(0) > 2r^p$ would be

$$\int_0^{r^g} f(t) \Delta t > \frac{r^g}{2}.$$

where $f : [0, r^g] \rightarrow [0, 1]$ is a non-decreasing function describing the distribution of the public's wage decisions (a general measure of overall r^p), and the LHS is called 'delta integral' such that

$$\int_0^{r^g} f(t) \Delta t = \begin{cases} \int_0^{r^g} f(t) dt & \text{if } \mathbb{T} \in \mathbb{R}, \\ \sum_{t=0}^{r^g-1} f(t) & \text{if } \mathbb{T} \in \mathbb{Z}. \end{cases}$$

This shows that time scale calculus, while nesting both continuous and discrete time as special cases, allows for even more flexible analysis of repeated dynamic interactions with heterogeneous time steps.

6.2. Macroeconomic Issues. Short Run Stabilization. As the paper takes a long-run view it is imperative to consider whether the findings are qualified in the presence of shocks. This is because some inflation targeting opponents (see eg Kohn (2003) or Friedman (2004)) have expressed concerns that a legislated numerical IT may reduce the policymaker's flexibility to react to shocks and stabilize output.

Our companion paper Libich (2010) utilizes the rigid framework to investigate these concerns in detail in a stochastic New Keynesian model. Existence of shocks requires an additional policy instrument, the interest rate, which is selected every r_i^g periods (and which can be thought of as short-run commitment as opposed to the long-run commitment examined here). The paper shows that allowing for disturbances does not alter the conclusions of the presented paper if the

³³For an interesting application of time scales in economics see Biles, Atici and Lebedinsky (2005). The authors model payments to an agent (eg capital income or dividends) arriving an unevenly spaced intervals.

IT is specified as a long-run objective - achievable on average over the business cycle. This is because shocks have a zero mean, ie they do not affect the average/trend level of inflation.³⁴

Sticky Expectations. While the analysis examined rigidity in wage setting, the insights also apply to the public's (infrequent) adjustment of expectations. Libich (2009) explicitly models this in a simplified version of the rigid framework by incorporating a cost of updating/processing information and allowing for the possibility of sticky expectations. This goes in the spirit of the models of 'rational inattention' (see eg Sims (2003), Reis (2006)) and bounded rationality (see eg Gigerenzer and Selten (2002)).

7. SUMMARY AND CONCLUSIONS

The paper proposes a simple framework that generalizes the timing structure of games - with emphasis on macroeconomic games. As most such real world games are arguably finite, dynamic and most importantly rigid, our framework combines these characteristics. We show that, similarly to reputation in repeated games, players' rigidity draws a link between successive periods and can serve as a commitment device. It can therefore enhance cooperation and eliminate inefficient outcomes from the set of possible equilibria.

The contribution of the paper is three-fold. First, on the game theoretic level it is shown that several conventional conclusions regarding the effect of Stackelberg (static) commitment may be refined or even qualified once more dynamics is allowed for. Second, on the level of monetary theory we apply the framework to the Kydland-Prescott-Barro-Gordon game and show the circumstances under which the influential time-inconsistency result no longer obtains. This application thus provides a theory of convergence to low inflation and high credibility that does not rely on any of the common channels: the Barro and Gordon (1983) reputation building, the Rogoff (1985) conservative central banker, nor the Walsh (1995) incentive contract. Third, on the empirical level we reconcile some conflicting findings reported in existing papers on the effect of inflation targeting, and its relationship to central bank independence.

8. REFERENCES

- Backus, David, and John Driffill. (1985), Rational Expectations and Policy Credibility Following a Change in Regime, *Review of Economic Studies* 52, 211-21.
- Ball, Laurence, and Niamh Sheridan. (2003), Does Inflation Targeting Matter?, (International Monetary Fund IMF Working Papers: 03/129).
- Barro, Robert J., and David B. Gordon. (1983), Rules, Discretion and Reputation in a Model of Monetary Policy, *Journal of Monetary Economics* 12, 101-21.
- Bernanke, Ben S., T. Laubach, Frederic S. Mishkin, and Adam Posen. (1999). Inflation targeting: Lessons from the international experience (Princeton University Press).
- Bernanke, Ben S., and Michael Woodford, eds., (2005). The inflation-targeting debate (University of Chicago Press, NBER Studies in Business Cycles, vol. 32. Chicago and London).
- Bewley, Truman F. (2002), Fairness, Reciprocity, and Wage Rigidity, (Cowles Foundation Yale University Cowles Foundation Discussion Papers: 1383).
- Bhaskar, V. (2002), On Endogenously Staggered Prices, *Review of Economic Studies* 69, 97-116.
- Biles, Daniel C., Ferhan M. Atici, and Alex Lebedinsky. (2005), An application of time scales to economics, *Mathematical and Computer Modelling*.
- Bohner, Martin, and Allan Peterson. (2001). *Dynamic equations on time scales* (Birkhauser Boston, 704 Inc., Boston, MA, 2001).
- Briault, Clive, Andrew Haldane, and Mervyn King. (1997), Independence and Accountability, in Iwao ed Kuroda, ed.: *Towards more effective monetary policy* (Macmillan Press in association with Bank of Japan, London).
- Calvo, Guillermo A. (1983), Staggered Prices in a Utility-Maximizing Framework, *Journal of Monetary Economics* 12, 383-98.
- Carroll, Christopher, and Jiri Slacalek. (2006), Sticky Expectations and Consumption Dynamics, *Computing in Economics and Finance*, 21.

³⁴The paper in fact finds the opposite, the policymaker's flexibility under an explicit long-run IT is likely to increase which reduces the volatility of both inflation and output in equilibrium. This is due to the 'anchoring' effect found empirically (eg Gurkaynak et al (2005)), which makes the interest rate instrument more effective not only in stabilization of inflation but also of output. For arguments and results in the same spirit see Orphanides and Williams (2005), Goodfriend (2003) and Mishkin (2004).

- Cho, I., and A. Matsui. (2005), Time Consistency in Alternating Move Policy Games, *Japanese Economic Review* 56 (3) 273-294. .
- Chortareas, Georgios, David Stasavage, and Gabriel Sterne. (2002), Does It Pay to Be Transparent? *International Evidence from Central Bank Forecasts*, Federal Reserve Bank of St. Louis Review 84, 99-117.
- Corbo, Vittorio, Oscar Landerretche, and Klaus Schmidt-Hebbel. (2001), Assessing Inflation Targeting after a Decade of World Experience, *International Journal of Finance and Economics* 6, 343-68.
- Cukierman, Alex, Steven B. Webb, and Bilin Neyapti. (1992), Measuring the Independence of Central Banks and Its Effect on Policy Outcomes, *World Bank Economic Review* 6, 353-98.
- de Haan, Jakob, Fabian Amtenbrink, and Sylvester C. W. Eijffinger. (1999), Accountability of Central Banks: Aspects and Quantification, *Banca Nazionale del Lavoro Quarterly Review* 52, 169-93.
- Debelle, Guy. (1997), Inflation Targeting in Practice, (International Monetary Fund IMF Working Papers: 97/35).
- Debelle, Guy, and Stanley Fischer. (1994), How independent should a central bank be?, in *Goals, Guidelines, and Constraints Facing Monetary Policymakers* (FRB of Boston, Conference Series No. 38).
- Eggertsson, Gauti B., and Eric Le Borgne. (2003), A Political Agency Theory of Central Bank Independence, (International Monetary Fund IMF Working Papers: 03/144).
- Eijffinger, Sylvester C. W., and Petra M. Geraats. (2006), How Transparent Are Central Banks?, *European Journal of Political Economy* 22(1), 1-21.
- Eijffinger, Sylvester, Eric Schaling, and Marco Hoeberichts. (1998), Central Bank Independence: A Sensitivity Analysis, *European Journal of Political Economy* 14, 73-88.
- Feige, Edgar L., and Douglas K. Pearce. (1976), Economically Rational Expectations: Are Innovations in the Rate of Inflation Independent of Innovations in Measures of Monetary and Fiscal Policy?, *The Journal of Political Economy* Vol. 84, No. 3, 499-522. .
- Fischer, Stanley. (1977), Long-Term Contracts, Rational Expectations, and the Optimal Money Supply Rule, *Journal of Political Economy* 85, 191-205.
- Friedman, Benjamin M. (2004), Why the Federal Reserve Should Not Adopt Inflation Targeting, *International Finance* 7, 129-36.
- Fry, M., D. Julius, L. Mahadeva, S. Roger, and G. Sterne. (2000), Key Issues in the Choice of a Monetary Policy Framework, in Mahadeva, and Sterne, eds.: *Monetary Frameworks in a Global Context* (Routledge, London).
- Gertler, Mark. (2003), Monetary Policy and Uncertainty: Adapting to a Changing Economy, symposium sponsored by the Federal Reserve Bank of Kansas City, (Jackson Hole, Wyoming, August 28 - 30, 2003).
- Gigerenzer, G. and R. Selten. (2002). *Bounded Rationality* (The MIT Press).
- Goodfriend, Marvin. (2003), Inflation Targeting in the United States?, (National Bureau of Economic Research Inc NBER Working Papers: 9981).
- Gurkaynak, Refet S., Brian Sack, and Eric Swanson. (2005), The Sensitivity of Long-Term Interest Rates to Economic News: Evidence and Implications for Macroeconomic Models, *American Economic Review* 95, 425-36.
- Hahn, Volker. (2006), Endogenous Attention of Price-Setters and Central Bank Conservatism, Heidelberg University, mimeo (Heidelberg University, mimeo).
- King, Mervin. (1998), The inflation target five years on, (London School Of Economics, 99).
- Kohn, D.L (2003), Remarks at the 28th Annual Policy Conference: Inflation Targeting: Prospects and Problems, (Federal Reserve Bank of St. Louis, St. Louis, Missouri).
- Kydland, F.E., and E.C. Prescott. (1977), Rules Rather Than Discretion: The Inconsistency of Optimal Plans, *Journal of Political Economy* 85, 473-91.
- Lagunoff, Roger, and Akihiko Matsui. (1997), Asynchronous Choice in Repeated Coordination Games, *Econometrica* 65, 1467-77.
- Libich, Jan. (2009), A Note on the Anchoring Effect of Explicit Inflation Targets, *Macroeconomic Dynamics*, 13(5).
- Libich, Jan (2010), Inflation Nutters? Modelling the Flexibility of Inflation Targeting, submitted
- Libich, Jan, and Petr Stehlík. (2008), *Macroeconomic Games on Time Scales*, *Dynamic Systems and Applications*, 5, pp274-278
- Mankiw, N. Gregory, and Ricardo Reis. (2002), Sticky Information versus Sticky Prices: A Proposal to Replace the New Keynesian Phillips Curve, *Quarterly Journal of Economics* 117, 1295-1328.
- Maskin, Eric, and Jean Tirole. (1988), A Theory of Dynamic Oligopoly, I: Overview and Quantity Competition with Large Fixed Costs, *Econometrica* 56, 549-69.
- Maskin, Eric, and Jean Tirole. (2001), Markov Perfect Equilibrium: I. Observable Actions, *Journal of Economic Theory* 100, 191-219.
- McCallum, B.T. (2003), Inflation Targeting for the United States, Shadow Open Market Committee, available at <http://www.somc.rochester.edu/May03/McCallum.pdf>.
- Mishkin, Frederic S. (2004), Why the Federal Reserve Should Adopt Inflation Targeting, *International Finance* 7, 117-27.
- Orphanides, Athanasios, and John C. Williams. (2005), Imperfect Knowledge, Inflation Expectations, and Monetary Policy, *Journal of Economic Dynamics and Control* Elsevier 29(11), 1807-8.
- Reis, Ricardo. (2006), Inattentive Consumers, *Journal of Monetary Economics* 53 (8).
- Rogoff, Kenneth. (1985), The Optimal Degree of Commitment to an Intermediate Monetary Target, *Quarterly Journal of Economics* 100, 1169-89.
- Sims, Christopher A. (2003), Implications of Rational Inattention, *Journal of Monetary Economics* 50 (3), 665-690.
- Sousa, P. . (2001), Independent and Accountable Central Banks and the European Central Bank, *European Integration online Papers* (EIoP) Vol. 5, N° 9; available at <http://eiop.or.at/eiop/texte/2001-009a.htm>.
- Taylor, John B. (1979), Staggered Wage Setting in a Macro Model, *American Economic Review* 69, 108-13.
- Tobin, James. (1982), Money and Finance in the Macroeconomic Process, *Journal of Money, Credit and Banking* 14 (2), 171-204.
- Waller, Christopher J., and Carl E. Walsh. (1996), Central-Bank Independence, Economic Behavior, and Optimal Term Lengths, *American Economic Review* 86, 1139-53.
- Walsh, Carl E. (1995), Optimal Contracts for Central Bankers, *American Economic Review* 85, 150-67.

Wen, Quan. (2002), Repeated Games with Asynchronous Moves, (Department of Economics Vanderbilt University Working Papers: 0204).

Willard, Luke. (2006), Does Inflation targeting Matter: A Reassessment, CEPS WP 120, Princeton University.

Wu, Thomas. (2004), Does inflation targeting reduce inflation? An analysis for the OECD industrial countries, (Banco Central do Brazil Working Paper 83).

APPENDIX A. PROOF OF PROPOSITION 1

Proof. For some g_n^L to be the policymaker's unique optimal play $\forall h_t$, two conditions need to be satisfied in that node n . Specifically, it must hold that $\{g_n^L\} = b(w^L)$ and $\{g_n^L\} = b(w^H)$, ie π^L is the unique best response to both w^L and w^H .

Induction Basis: $\mathbf{n}^g = \mathbf{N}^g$ under $\mathbf{R} = \mathbf{0}$: This special case is illustrative of the intuition of the proof. Due to $r^g > r^p$ we have $T(r^g, r^p) = r^g$ and therefore $N^g = 1$ and $N^p = r^g$. Solving backwards, we know that $p_{n>1}^* \in b(g_1)$ due to perfect information in $n^p > 1$. Further, from the public's rationality and complete information it follows that $p_1^* \in b(g_1)$. Using this, the two required conditions for $\{g_1^L\} = b(w^L)$ and $\{g_1^L\} = b(w^H)$ are the following

$$(16) \quad \underbrace{ar^g}_{(\pi^L, w^L)} > \underbrace{cr^p}_{(\pi^H, w^L)} + \underbrace{d(r^g - r^p)}_{(\pi^H, w^H)},$$

$$(17) \quad \underbrace{br^p}_{(\pi^L, w^H)} + \underbrace{a(r^g - r^p)}_{(\pi^L, w^L)} > \underbrace{dr^g}_{(\pi^H, w^H)}.$$

The left-hand side (LHS) and the right-hand side (RHS) will throughout report the policymaker's payoffs from playing, in a certain node, π^L and π^H respectively. Examine (16) for example. It assumes p_1^L and states that if the policymaker inflates (plays g_1^H), he manages to boost output getting the payoff c . This however only lasts for r^p periods, after which the public would switch to w^H and 'punish' the policymaker with the payoff d for the rest of the rigid stage game. Rearranging these yields

$$(18) \quad r^g > \overline{r^g}(0) = \frac{c-d}{a-d}r^p = \frac{a-b}{a-d}r^p \stackrel{(6)}{=} 2r^p,$$

where the two fractions are the result of (16) and (17) respectively using the general payoff constraints in (7), whereas the last term also uses the specific payoff from (6).³⁵ This implies that all $\frac{r^g}{r^p} = \{3, 4, 5, \dots\}$ uniquely deliver Ramsey SPNE, and that in the case of $\frac{r^g}{r^p} = 2$ there exists both Ramsey and non-Ramsey SPNE.

Induction Basis: $\mathbf{n}^g = \mathbf{N}^g$ under $\mathbf{R} = (\mathbf{0}, \mathbf{1})$: From Definition 1 it follows that the number of the policymaker's moves in the rigid stage game is $N^g = \frac{T(r^g, r^p)}{r^g}$. The two conditions analogous to (16) and (17) are the following

$$(19) \quad ar^g > cr^p R + d(r^g - r^p R) \quad \text{and} \quad br^p R + a(r^g - r^p R) > dr^g,$$

and hence

$$(20) \quad r^g > \frac{c-d}{a-d}Rr^p = \frac{a-b}{a-d}Rr^p \stackrel{(6)}{=} 2Rr^p,$$

which is, due to $R < 1$, weaker than (18) for all constraints satisfying (7).

Inductive Step: $\mathbf{n}^g + \mathbf{1} \rightarrow \mathbf{n}^g$ (if applicable, ie if $1 \leq n^g < N^g$): We assume that the policymaker's unique best play in the $(n^g + 1)$ -th step is L regardless of the public's preceding play (ie that g_{n+1} is history-independent), and we attempt to prove that this implies the same assertion for the n^g -th step. Intuitively, this means that if the policymaker inflates he finds it optimal to immediately disinflate. Two scenarios are possible for each of the two conditions

³⁵Note that under the general constraints from (7) the conditions implied by (16) and (17) are equivalent, which will be the case for all pairs of such conditions.

of interest, $\{g_n^L\} = b(w^L)$ and $\{g_n^H\} = b(w^H)$. The disinflation will either be costly - lacking credibility (due to excessive wages w^H the payoff b occurs for at least one period), or costless (only accompanied by w^L).

Whether the disinflation is costly or costless depends on the public's play preceding the disinflation, which in turn depends on the recursive scheme in (8) and the public's preferences. From the public's utility function in (3) in which the payoffs in period t is only a function of the opponent's action in t , and from the finite horizon of the rigid stage game it follows that the public always plays the static best response to either the immediately preceding or the immediately following move of the policymaker. Therefore, the costly disinflation conditions for all relevant nodes of the policymaker - analogous to (16) and (17) respectively - are the following

$$(21) \quad ar^g + a[r^p - (r^p - k_{n+1})] > ck_n + d(r^g - k_n) + b[r^p - (r^p - k_{n+1})],$$

$$(22) \quad bk_n + a(r^g - k_n) + a[r^p - (r^p - k_{n+1})] > dr^g + b[r^p - (r^p - k_{n+1})],$$

where the b terms on the RHS express the total cost of disinflation. Similarly the costless disinflation conditions analogous to (16) and (17) are

$$(23) \quad ar^g > ck_n + d[r^g - k_n - (r^p - k_{n+1})] + c(r^p - k_{n+1}),$$

$$(24) \quad bk_n + a(r^g - k_n) > d[r^g - (r^p - k_{n+1})] + c(r^p - k_{n+1}),$$

where the last c components on the RHS express the output gain from the public's switch prior to the start of the disinflation. Note again that under the general constraints (7) the two conditions in each set yield the same inequality. Which of these two sets of conditions is relevant to a certain n^g (and hence what the value of \bar{R} in (9) is) depends on the public's payoffs $\{q, v, x, z\}$, and importantly on k_{n+1} . Specifically, if

$$(25) \quad z(r^p - k_{n+1}) + vk_{n+1} \geq x(r^p - k_{n+1}) + qk_{n+1},$$

then (21)-(22) obtain, otherwise (23)-(24) are the appropriate conditions. Rearranging yields

$$(26) \quad k_{n+1} \leq \frac{z - x}{z - x + q - v} r^p \stackrel{(6)}{=} \frac{r^p}{2}.$$

The following result will dramatically simplify the proof.

Lemma 1. *Consider the general rigid stage game in which (7) holds. If $\{g_1^L\} = b(p_1^L) = b(p_1^H)$ then $\forall n$, $\{g_n^L\} = b(w^L) = b(w^H)$. Therefore, the former condition regarding the initial simultaneous move is, $\forall R$, sufficient to uniquely ensure Ramsey SPNE in the rigid stage game.*

Proof. Due to the fact that k_n attains its unique maximum value, r^p , at $n^g = 1$, it suffices to show that the strength of all four conditions in (21)-(24) is non-decreasing in k_n . In doing so let us first assume that the condition for the policymaker's last move, $\{g_N^L\} = b(w^L) = b(w^H)$, is satisfied, ie (20) holds.

Equations (21)-(24) can be, respectively, rearranged into

$$r^g > \frac{(c-d)k_n - (a-b)k_{n+1}}{a-d} \quad \text{and} \quad r^g > \frac{a-b}{a-d}(k_n - k_{n+1}),$$

$$r^g > \frac{(c-d)(k_n + r^p - k_{n+1})}{a-d} \quad \text{and} \quad r^g > \frac{(a-b)k_n + (c-d)(r^p - k_{n+1})}{a-d}.$$

Recall from (8) that k_{n+1} is a function of k_n . Since in all four conditions the RHS is decreasing in k_{n+1} we need to use $k_{n+1} = k_n - Rr^p$ from (8) to substitute away k_{n+1} . This yields

$$(27) \quad r^g > \frac{(c-d-a+b)k_n + (a-b)Rr^p}{a-d} \quad \text{and} \quad r^g > \frac{a-b}{a-d}Rr^p,$$

$$(28) \quad r^g > \frac{(c-d)r^p(1+R)}{a-d} \quad \text{and} \quad r^g > \frac{(a-b-c+d)k_n + (c-d)r^p(1+R)}{a-d}.$$

The RHS of all four inequalities is non-decreasing in k_n for all values satisfying the general constraints in (7). This implies that at $n^g = 1$ the condition will be the strongest of all n^g (in a weak sense). It is also apparent that it is strictly stronger than the condition for the policymaker's last move which we assumed to hold, (20), since $k_N < k_1 = r^p$. The realization that for $R = 0$ we have $N^g = 1$ finishes the proof of Lemma 1. \square

Continuing the proof of Proposition 1 and substituting $k_{n+1} = k_2 = r^p(1-R)$ into (26) yields

$$(29) \quad R \geq \bar{R} = \frac{q-v}{z-x+q-v} \stackrel{(6)}{=} \frac{1}{2},$$

which features in (9) and (10). Substituting $k_n = k_1 = r^p$ into (27) and (28) yields, together with (7) and (18), equation (9). Using (6) with (9) then yields (10). Noting that $\bar{r}^g(R)$ in (9) is increasing in c and d and decreasing in a and b implies the last claim and completes the proof of Proposition 1. \square

APPENDIX B. PROOF OF THEOREM 1

Proof. We start by noting that the value of δ_p only affects the necessary and sufficient conditions (9) of Proposition 1 through the value of \bar{R} (ie at what asynchrony R the conditions apply rather than what conditions apply). It then follows that the finding of Lemma 1 still holds under the public's impatience. Formally, the generalization of (25) under discounting is, using $k_{n+1} = k_2 = r^p(1-R)$, the following

$$(30) \quad z \sum_{t=1}^{r^p-k_{n+1}} \delta_p^{t-1} + v \sum_{t=r^p-k_{n+1}+1}^{r^p} \delta_p^{t-1} \geq x \sum_{t=1}^{r^p-k_{n+1}} \delta_p^{t-1} + q \sum_{t=r^p-k_{n+1}+1}^{r^p} \delta_p^{t-1}.$$

It is apparent that the public's impatience reduces the value of \bar{R} and hence may alter the *sufficient* condition for Ramsey SPNE. Instead of deriving analytically $\bar{\delta}_p$ from (30) we focus on the extreme case $\bar{\delta}_p = \delta_p = 0$ which is a sufficiently low threshold for all $\{r^g, r^p, q, v, x, z\}$ satisfying (7). Under $\delta_p = 0$, (30) becomes $z \geq x$ from which it follows that $\bar{R} = 0$. Therefore, (23) and (24) no longer apply and (21) and (22) become the relevant conditions for all $n^g, R = (0, 1]$, and for all $\{a, b, c, d, q, v, x, z\}$ satisfying (7).

Hence we need to show that any $r^g > r^p$ satisfy the following two conditions from (9): (i) under $R = 0$ it holds that $\frac{r^g}{r^p} \geq \frac{a-b}{a-d}$ and (ii) $\forall R = (0, 1)$ it is true that $\frac{r^g}{r^p} \geq \frac{a-b}{a-d}R$.³⁶ In terms of (ii) realize that any $r^g > r^p$ have, from the definition of R , the property that $\frac{r^g}{r^p} \geq 1+R$. This implies that claim (ii) can be rewritten as $1+R \geq \frac{a-b}{a-d}R$. Divide both sides by R to obtain $\frac{1}{R} + 1 \geq \frac{a-b}{a-d}$. To see that this is satisfied utilize two characteristics. First, $\frac{1}{R} + 1 > 2$ since $R < 1$. Second, rearrange $a \geq 2d - b$ into $2 \geq \frac{a-b}{a-d}$. Combining these gives $\frac{1}{R} + 1 > 2 \geq \frac{a-b}{a-d}$ which completes the proof of (ii). In terms of (i) note that under $R = 0$ all $r^g > r^p$ satisfy $\frac{r^g}{r^p} \geq 2$. Using this jointly with $2 \geq \frac{a-b}{a-d}$ completes the proof. \square

APPENDIX C. PROOF OF THEOREM 2

Proof. We need to prove an extension of Lemma 1 under $\delta_g < 1$ (note that the proof of Theorem 1 argued that δ_p does not affect the necessary and sufficient conditions except for the value of

³⁶We have used the property of (7) to collapse the two equalities in (9).

\bar{R}). Under $\delta_g < 1$, (22) and (24) become³⁷

$$(31) \quad b \sum_{t=1}^{k_n} \delta_g^{t-1} + a \sum_{t=k_n+1}^{r^g} \delta_g^{t-1} + a \sum_{t=r^g+1}^{r^g+k_n+1} \delta_g^{t-1} > d \sum_{t=1}^{r^g} \delta_g^{t-1} + b \sum_{t=r^g+1}^{r^g+k_n+1} \delta_g^{t-1},$$

$$(32) \quad b \sum_{t=1}^{k_n} \delta_g^{t-1} + a \sum_{t=k_n+1}^{r^g} \delta_g^{t-1} > d \sum_{t=1}^{r^g-r^p+k_n+1} \delta_g^{t-1} + c \sum_{t=r^g-r^p+k_n+1}^{r^g} \delta_g^{t-1}.$$

Focusing on (31) it can be rearranged into

$$(d-b) \sum_{t=1}^{k_n} \delta_g^{t-1} - (a-d) \sum_{t=k_n+1}^{r^g} \delta_g^{t-1} - (a-b) \sum_{t=r^g+1}^{r^g+k_n+1} \delta_g^{t-1} < 0.$$

Use $a-b = (a-d) + (d-b)$ and split the first series to obtain

$$(a-b) \sum_{t=1}^{k_n} \delta_g^{t-1} - (a-d) \sum_{t=1}^{r^g} \delta_g^{t-1} - (a-b) \sum_{t=r^g+1}^{r^g+k_n+1} \delta_g^{t-1} < 0.$$

Add $\sum_{t=k_n+1}^{r^g} \delta_g^{t-1}$ to both sides and collect the terms

$$(a-b) \sum_{t=1}^{r^g} \delta_g^{t-1} - (a-d) \sum_{t=1}^{r^g} \delta_g^{t-1} < (a-b) \sum_{t=k_n+1}^{r^g+k_n+1} \delta_g^{t-1}.$$

Adding up the series on the RHS we obtain

$$(a-b) \sum_{t=1}^{r^g} \delta_g^{t-1} - (a-d) \sum_{t=1}^{r^g} \delta_g^{t-1} < (a-b) \delta_g^{k_n} \frac{1 - \delta_g^{r^g+k_n+1-k_n}}{1 - \delta_g}.$$

Since the RHS is decreasing in k_{n+1} , we need to use $k_{n+1} = k_n - Rr^p$ from (8) to substitute away k_{n+1} . This yields

$$(a-b) \sum_{t=1}^{r^g} \delta_g^{t-1} - (a-d) \sum_{t=1}^{r^g} \delta_g^{t-1} < (a-b) \delta_g^{k_n} \frac{1 - \delta_g^{r^g - Rr^p}}{1 - \delta_g}.$$

Note that the RHS is increasing in k_n , ie the condition is the strongest at $n^g = 1$ since k_n has a unique maximum in k_1 . The same can be analogously shown for (32). Realizing that due to $k_N < k_1 = r^p$ and discounting the condition for $\{g_N^L\} = b(w^L) = b(w^H)$ is strictly weaker than for $\{g_1^L\} = b(w^L) = b(w^H)$, and that under $R = 0$ we have $N^g = 1$ finishes the proof \square

APPENDIX D. PROOF OF THEOREM 3

Proof. Claim (i): Realize that (11) implies $0 < \bar{\delta}_g < 1$ for all assumed values. First, the direct consequence of (7), $|a-d| < |c-b|$, ensures that the argument of the square root is positive. Moreover, the inequalities $a > d$ and $c > b$ imply that this argument is less than one.

It is apparent in (9) that the *strongest* possible necessary and sufficient condition (highest $\bar{r}^g(R)$) obtains under costless disinflation if the public's payoffs $\{q, v, x, z\}$ are such that $\bar{R} \rightarrow 1$. Furthermore, we have shown in Theorem 1 that the public's impatience weakens the sufficient conditions. Therefore, it suffices to focus on the analog of (24) under $\delta_g < 1 = \delta_p$, (32),³⁸

³⁷It again suffices to consider these two conditions since under the general constraints (7) equations (21) and (23) yield the same respective conditions.

³⁸Again the condition implied by (23) will be equivalent to (32).

assuming that $k_n = k_1 = r^p$ and $k_{n+1} = k_2 \rightarrow 0$ (the latter leading to $\bar{R} \rightarrow 1$). Substituting this into (32) yields

$$(33) \quad (a-d) \sum_{t=r^p+1}^{r^g-r^p} \delta_g^{t-1} > (d-b) \sum_{t=1}^{r^p} \delta_g^{t-1} + (c-a) \sum_{t=r^g-r^p+1}^{r^g} \delta_g^{t-1}.$$

Therefore, in this proof it suffices to show that (11) implies (33). First, let us realize that (11) can be rewritten as

$$\delta_g^{r^p} > \frac{c-b+d-a}{c-b},$$

which can be rearranged into

$$0 < 1 - \frac{d-b+c-a}{a-d} \frac{1-\delta_g^{r^p}}{\delta_g^{r^p}}.$$

Since $\delta_g^{2r^p} > 0$, it is also true that

$$0 < \delta_g^{2r^p} \left(1 - \frac{d-b+c-a}{a-d} \frac{1-\delta_g^{r^p}}{\delta_g^{r^p}} \right).$$

Consequently, for each $\delta_g = (0, 1)$ there exists $\bar{r}^g \in \mathbb{N}$ such that for all $r^g > \bar{r}^g$

$$\delta_g^{r^g} < \delta_g^{2r^p} \left(1 - \frac{d-b+c-a}{a-d} \frac{1-\delta_g^{r^p}}{\delta_g^{r^p}} \right).$$

Multiplying both sides by $-(a-d)\delta_g^{r^p} > 0$ and dividing by $\delta_g^{2r^p}$ we obtain

$$(a-d)\delta_g^{r^p} \left(1 - \delta_g^{r^g-2r^p} \right) > (d-b+c-a)(1-\delta_g^{r^p}).$$

Moreover, we divide both sides by $1-\delta_g > 0$ and split the right-hand side

$$(a-d)\delta_g^{r^p} \frac{1-\delta_g^{r^g-2r^p}}{1-\delta_g} > (d-b) \frac{1-\delta_g^{r^p}}{1-\delta_g} + (c-a) \frac{1-\delta_g^{r^p}}{1-\delta_g}.$$

Note that the three fractions are in fact partial sums of a geometric series with quotient δ_g

$$(34) \quad 0 > (d-b) \sum_{t=1}^{r^p} \delta_g^{t-1} - (a-d) \sum_{t=r^p+1}^{r^g-r^p} \delta_g^{t-1} + (c-a) \sum_{t=1}^{r^p} \delta_g^{t-1}.$$

Finally, we realize that

$$\sum_{t=1}^{r^p} \delta_g^{t-1} > \sum_{t=r^g-r^p+1}^{r^g} \delta_g^{t-1},$$

which, in combination with $c > a$ and equation (34), implies that (33) holds. This completes the proof of claim (i).

Claim (ii): Realize that (12) implies $0 < \underline{\delta}_g < 1$ for all assumed values since $a > d$ and $|d-b| < |a-b|$ (from (7)). It is apparent in (9) that the *weakest* possible necessary and sufficient condition (lowest $\bar{r}^g(R)$) obtains under costly disinflation if the public's payoffs $\{q, v, x, z\}$ are such that $\bar{R} \rightarrow 0$. Furthermore, we have shown in Theorem 1 that the public's impatience weakens the sufficient conditions. Therefore, we can focus on the analog of (22) under $0 = \delta_p \leq \delta_g < 1$,

(31), assuming that $k_{n+1} = k_2 \rightarrow k_n = k_1 = r^p$ (the latter leading to $\bar{R} \rightarrow 0$). Substituting this into (31) yields

$$(35) \quad (a-d) \sum_{t=r^p+1}^{r^g} \delta_g^{t-1} + (a-b) \sum_{t=r^g+1}^{r^g+r^p} \delta_g^{t-1} > (d-b) \sum_{t=1}^{r^p} \delta_g^{t-1}.$$

Using the formula for a finite sum of a geometric series and rearranging yields

$$(1 - \delta_g^{r^p})[(a-b)\delta_g^{r^p} - (d-b)] \stackrel{(6)}{=} (1 - \delta_g^{r^p})(2\delta_g^{r^p} - 1) > 0.$$

The conditions under which this is *not* satisfied are reported in (12). The fact that there may be no Ramsey SPNE implies that the inequality in (12) must be strict. \square

APPENDIX E. PROOF OF PROPOSITION 2

Proof. Under the policymaker's impatience the conditions analogous to (16) and (17) become

$$(36) \quad a \sum_{t=1}^{r^g} \delta_g^{t-1} > c \sum_{t=1}^{r^p} \delta_g^{t-1} + d \sum_{t=r^p+1}^{r^g} \delta_g^{t-1} \quad \text{and} \quad b \sum_{t=1}^{r^p} \delta_g^{t-1} + a \sum_{t=r^p+1}^{r^g} \delta_g^{t-1} > d \sum_{t=1}^{r^g} \delta_g^{t-1},$$

which can be rewritten into

$$a \frac{1 - \delta_g^{r^g}}{1 - \delta_g} > c \frac{1 - \delta_g^{r^p}}{1 - \delta_g} + d \delta_g^{r^p} \frac{1 - \delta_g^{r^g-r^p}}{1 - \delta_g} > \quad \text{and} \quad b \frac{1 - \delta_g^{r^p}}{1 - \delta_g} + a \delta_g^{r^p} \frac{1 - \delta_g^{r^g-r^p}}{1 - \delta_g} > d \frac{1 - \delta_g^{r^g}}{1 - \delta_g}.$$

Dividing by $(1 - \delta_g)$, taking the logarithms and rearranging yields (13) which can only be satisfied if (14) holds. Note two properties which follow from (13). First, the arguments of the logarithms in (13) are positive if and only if (14) holds. Second, both the base and the argument of the logarithms in (13) are then (strictly) between 0 and 1 - to see this realize that

$$0 < \frac{c-d}{a-d} \delta_g^{r^p} - \frac{c-a}{a-d} = \frac{a-b}{a-d} \delta_g^{r^p} - \frac{d-b}{a-d} < \frac{c-d}{a-d} - \frac{c-a}{a-d} = \frac{a-b}{a-d} - \frac{d-b}{a-d} = 1.$$

This implies that $\bar{r}^g(0)$ in (13) is increasing in r^p and, after simple manipulations, that it is also increasing in c and d and decreasing in a and b . Proving that $\bar{r}^g(0)$ is also decreasing in δ_g requires further calculations. Focus on the first logarithm of (13) and rewrite the equation into

$$\bar{r}^g(0) = \frac{\ln\left(\frac{a-b}{a-d} \delta_g^{r^p} - \frac{d-b}{a-d}\right)}{\ln \delta_g}.$$

Our task is to show that $\bar{r}^g(0)$ is decreasing in δ_g on the considered domain

$$D := \left(\sqrt[r^p]{\frac{d-b}{a-b}}, 1 \right).$$

For the sake of clarity, we simplify the notation by defining

$$\gamma := \frac{a-b}{a-d}, \quad \omega := \frac{d-b}{a-d}, \quad r := r^p, \quad \delta := \delta_g.$$

Therefore, we want to show that the function

$$f(\delta) = \frac{\ln(\gamma \delta^r - \omega)}{\ln \delta},$$

is decreasing in δ , or equivalently that $f'(\delta) < 0$ on D . Obviously,

$$\begin{aligned} f'(\delta) &= \frac{\frac{r\gamma\delta^{r-1}}{\gamma\delta^r - \omega} \ln \delta - \frac{1}{\delta} \ln(\gamma\delta^r - \omega)}{\ln^2 \delta} \\ &= \frac{r\gamma\delta^r \ln \delta - (\gamma\delta^r - \omega) \ln(\gamma\delta^r - \omega)}{\delta(\gamma\delta^r - \omega) \ln^2 \delta}. \end{aligned}$$

Since the denominator is always positive, it suffices to show that on the considered domain D

$$r\gamma\delta^r \ln \delta - (\gamma\delta^r - \omega) \ln(\gamma\delta^r - \omega) < 0,$$

or equivalently

$$\phi(\delta) := r\gamma\delta^r \ln \delta < (\gamma\delta^r - \omega) \ln(\gamma\delta^r - \omega) =: \psi(\delta).$$

Taking into account definitions of γ and ω we observe that $\phi(1) = 0 = \psi(1)$. Therefore it suffices to show that $\phi'(\delta) > \psi'(\delta)$ for all $\delta \in D$. But this holds since

$$\begin{aligned} \phi'(\delta) &> \psi'(\delta), \\ r^2\gamma x^{r-1} \ln \delta + r\gamma x^{r-1} &> r\gamma x^{r-1} \ln(\gamma\delta^r - \omega) + r\gamma x^{r-1}, \\ r \ln \delta &> \ln(\gamma\delta^r - \omega), \\ \delta^r &> \gamma\delta^r - \omega, \\ \delta_g^{r^p} &> \frac{a-b}{a-d} \delta_g^{r^p} - \frac{d-b}{a-d}, \\ (a-d)\delta_g^{r^p} &> (a-b)\delta_g^{r^p} - (d-b), \\ 0 &> (d-b)(\delta_g^{r^p} - 1), \end{aligned}$$

where the last inequality is trivially satisfied since $d > b$ and $\delta_g < 1$. Noting that the two elements of (13) equal for all values of the general game completes the proof. \square